

Principles of Phase Doppler Anemometry

Dantec Measurement Technology

<http://www.dantecmt.com>

Contents

- **General Features**
- **Optical principles**
- **Light scattering considerations**
- **Phase-diameter relationship**
- **Sources of uncertainty**
- **DualPDA technique**
- **Application examples**

General features of PDA

- **Extension of the LDA principle**
- **Simultaneous measurement of velocity (up to 3 components) and size of spherical particles as well as mass flux, concentration etc.**
- **First publication by Durst and Zaré in 1975**
- **First commercial instrument in 1984**
- **Non-intrusive measurement (optical technique), on-line and in-situ**
- **Absolute measurement technique (no calibration required)**
- **Very high accuracy**
- **Very high spatial resolution (small measurement volume)**

Preconditions for the application of PDA

- **Optical access to the measurement area (usually from two directions)**
- **Sphericity of particles (droplets, bubbles, solids)**
- **Homogeneity of particle medium**
(slight inhomogeneities may be tolerated if the concentration of the inhomogeneities is low and if the size of the inhomogeneities is much smaller than the wavelength used)
- **Refractive indices of the particle and the continuous medium must usually be known**
- **Particle size between ca. 0.5 μm and several millimeters**
- **Max. particle number concentration is limited**

Principle setup of PDA

Optical parameters of a PDA setup:

- Beam intersection angle θ
- Scattering angle φ
- Elevation angle ψ
- Polarization (parallel or perpendicular to scattering plane)
- Shape and size of detector aperture

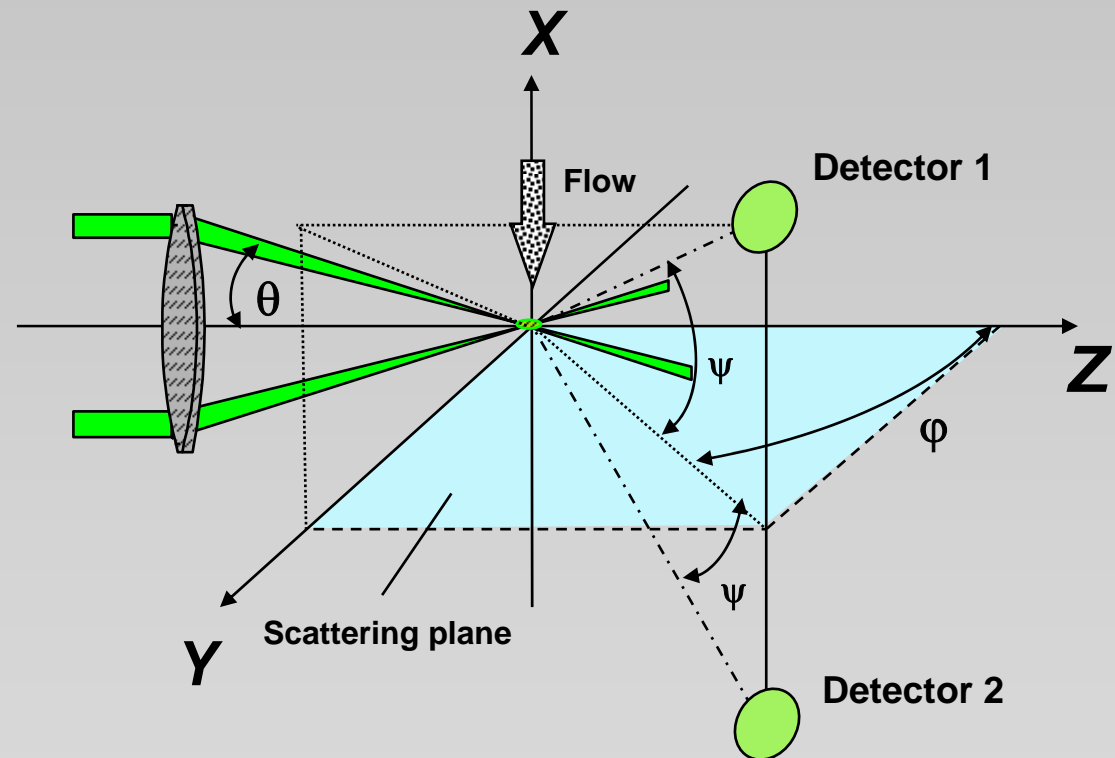

Optical principle of PDA

- A particle scatters light from two incident laser beams
- Both scattered waves interfere in space and create a beat signal with a frequency which is proportional to the velocity of the particle
- Two detectors receive this signal with different phases
- The phase shift between these two signals is proportional to the diameter of the particle

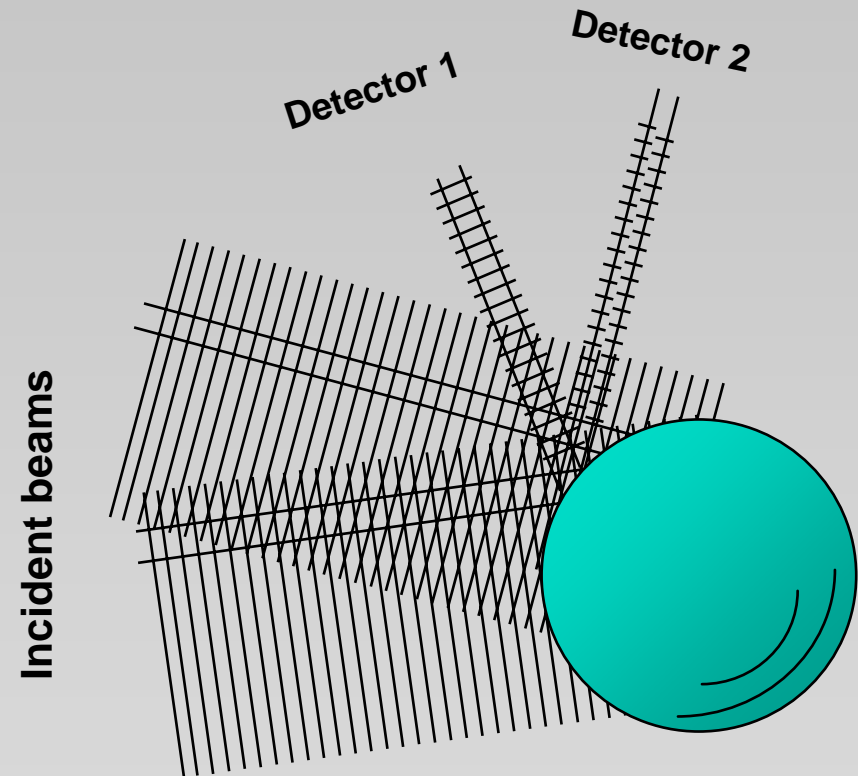

Light scattering principles

The principle of the PDA technique is the scattering of plane lightwaves by spherical particles.

A lightwave is fully described by:

- wavelength
- intensity
- polarization
- phase

Scattering is composed of:

- diffraction
- reflection
- refraction
- absorption

An exact description of the scattering of light by a homogeneous sphere is given by the full solution of Maxwell's equations formulated by Mie in 1908.

Geometric optics (Snell's law) is a simplified way to describe light scattering.

Scattering modes

The intensity of the incident ray is partly reflected and refracted.

The intensity ratio is given by the Fresnel coefficients and depends on the incident angle, polarization and relative refractive index.

The scattering angle is given by Snell's law.

The phase is given by the optical path length of the ray.

Most of the intensity is contained in the first three scattering modes.

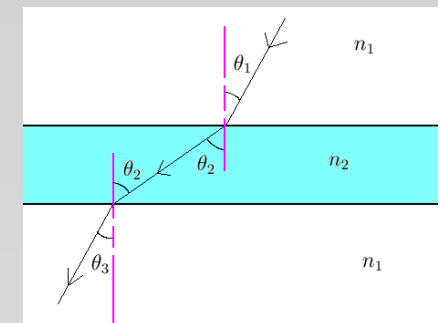
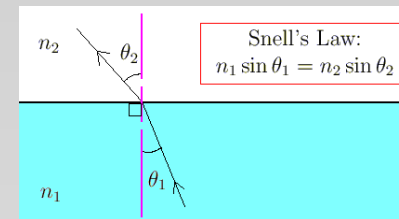
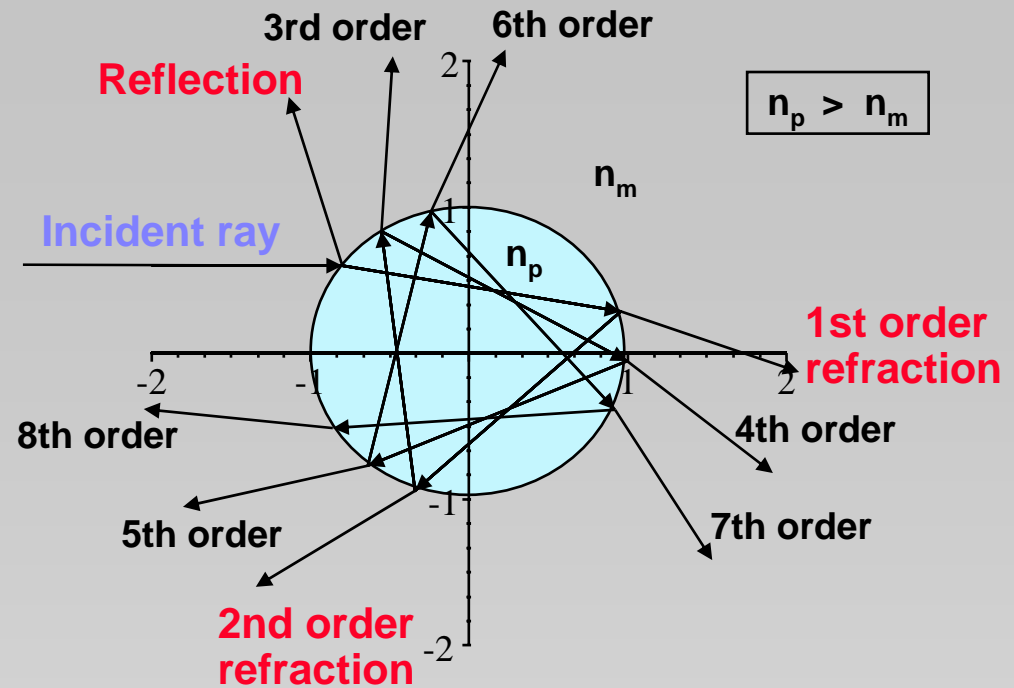

$$\begin{aligned} \theta_2 &= \sin^{-1} \left(\frac{n_1}{n_2} \sin \theta_1 \right) \\ \theta_3 &= \sin^{-1} \left(\frac{n_2}{n_1} \sin \theta_2 \right) \\ &= \sin^{-1} \left(\frac{n_2}{n_1} \sin \left(\sin^{-1} \left(\frac{n_1}{n_2} \sin \theta_1 \right) \right) \right) \\ &= \sin^{-1} (\sin \theta_1) \\ &= \theta_1 \end{aligned}$$

Light scattering by droplets and bubbles

Water droplet in air

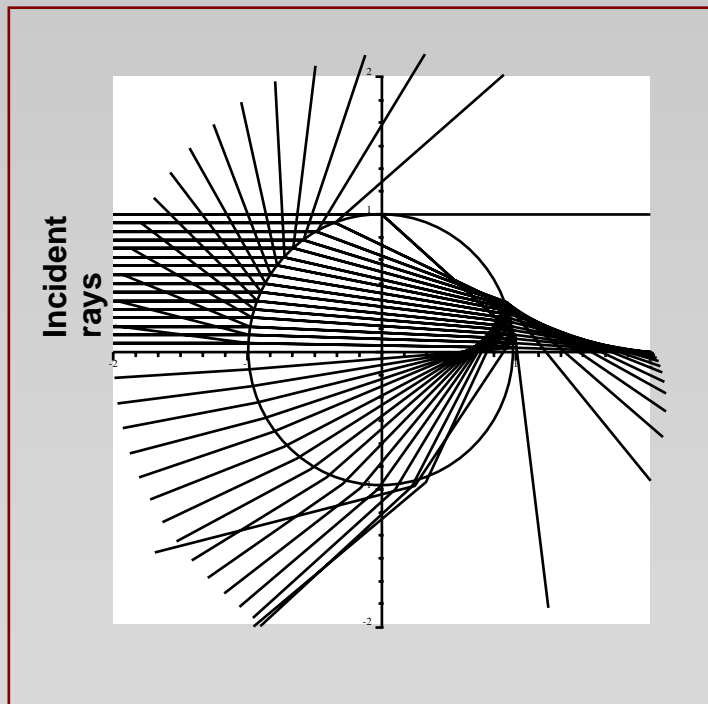

Air bubble in water

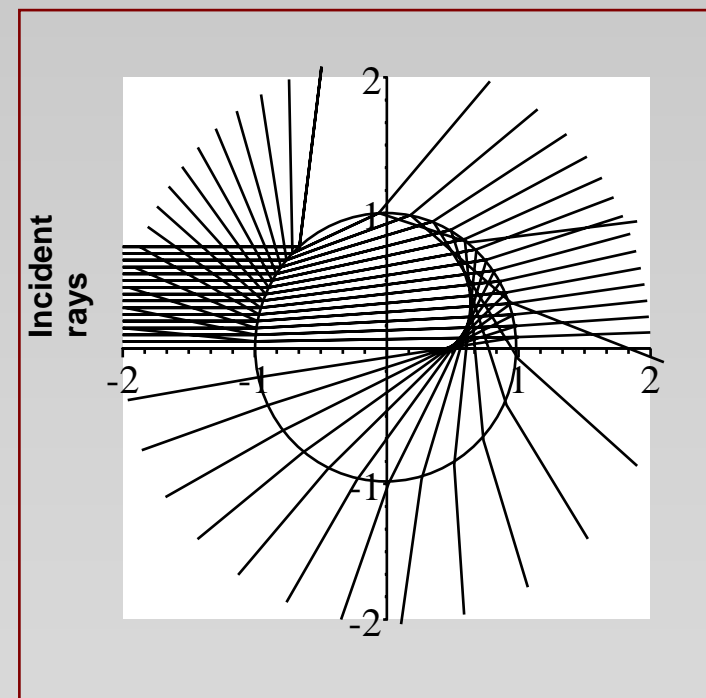

Phase relationships

The phase shift between two detectors is:

For reflection:

$$\Phi = \frac{2 \pi d_p}{\lambda} \frac{\sin \theta \sin \psi}{\sqrt{2(1 - \cos \theta \cos \psi \cos \phi)}}$$

For 1st order refraction:

$$\Phi = \frac{-2 \pi d_p}{\lambda} \frac{n_{rel} \sin \theta \sin \psi}{\sqrt{2(1 + \cos \theta \cos \psi \cos \phi)} (1 + n_{rel}^2 - n_{rel} \sqrt{2(1 + \cos \theta \cos \psi \cos \phi)})}$$

No calibration constant is contained in these equations.

Phase - diameter linearity

- A linear relationship between measured phase difference and particle diameter only exists, if the detector is positioned such that one light scattering mode dominates.
- Simultaneous detection of different scattering modes of comparable intensity leads to non-linearities in the phase-diameter relationship.

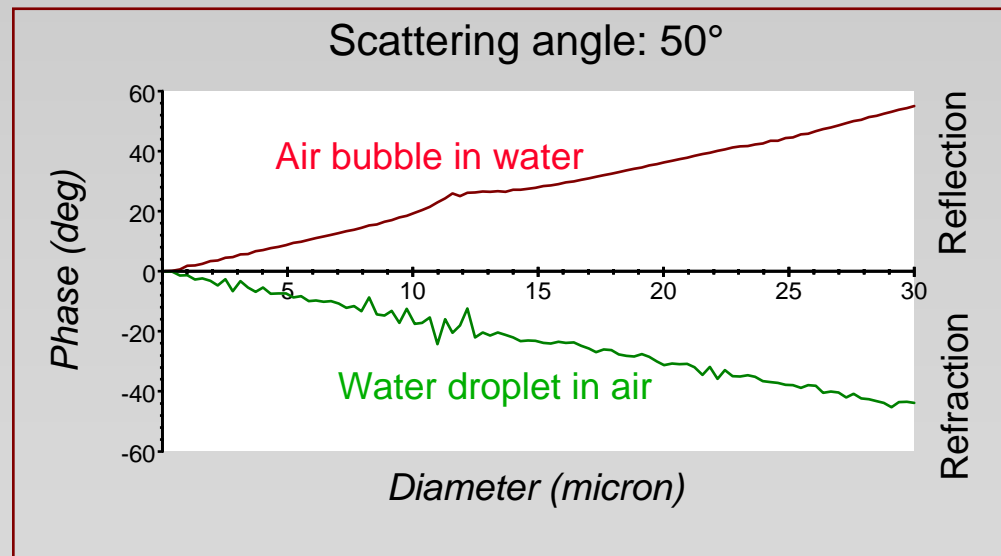

Intensity of scattered light

- The scattered light intensity from the different scattering modes varies at different scattering angles.
- The scattering intensity also depends on the polarization orientation of the incident light.

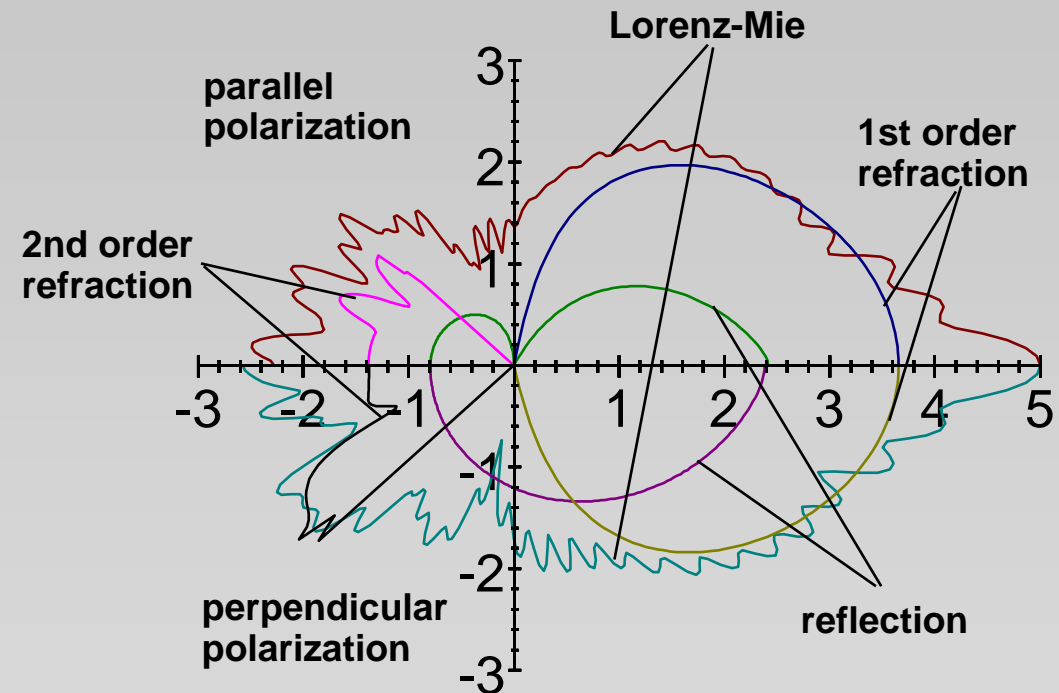

2π ambiguity in a two-detector system

- The phase difference increases with increasing particle size.
- Since phase is a modulo 2π function, it cannot exceed 2π , i.e. 360° .
- Therefore, if a particle has a size that causes the phase to go beyond a 2π jump, a two-detector PDA cannot discriminate between this size and a much smaller particle.

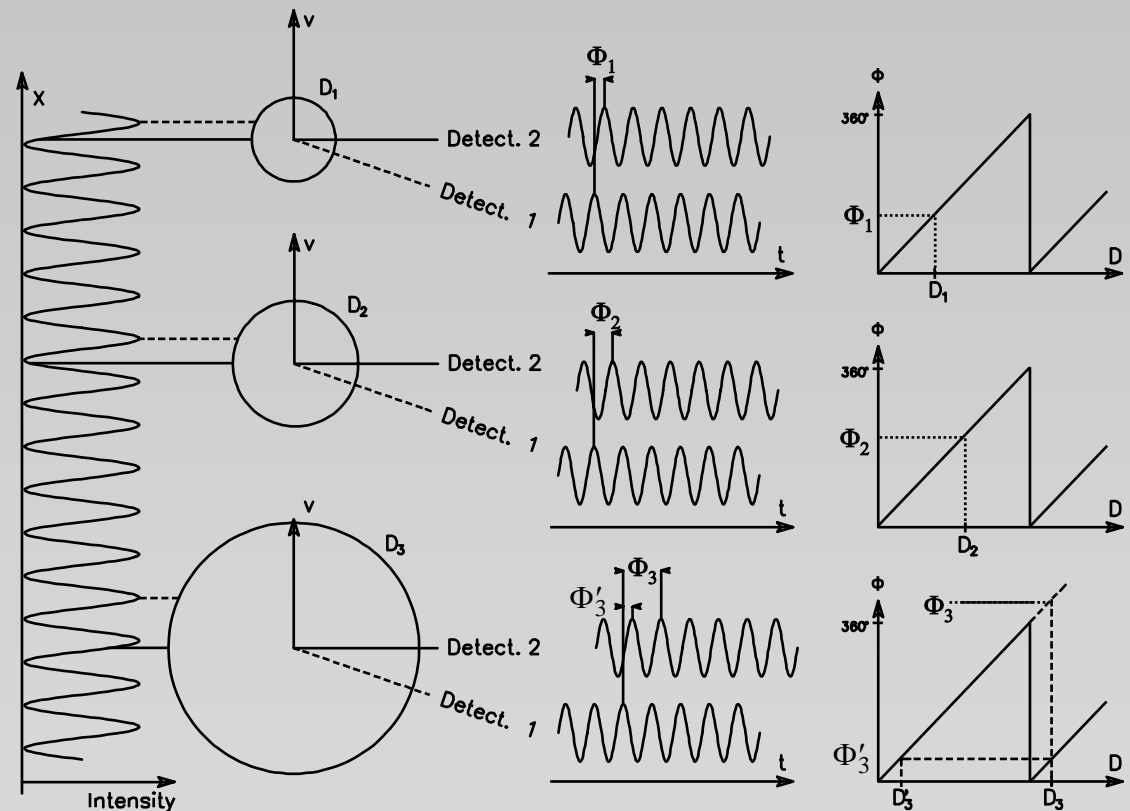

3-detector setup

- Overcoming the 2π ambiguity
- Increasing the measurable size range
- Maintaining a high measurement resolution

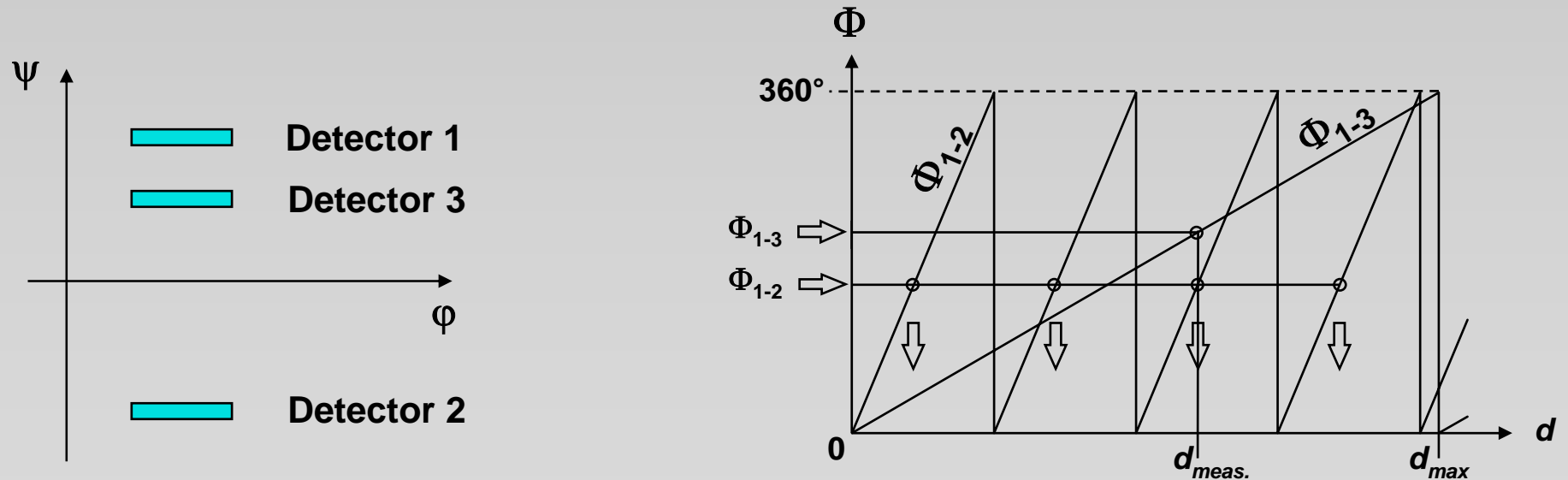

Dantec 57X40 FiberPDA

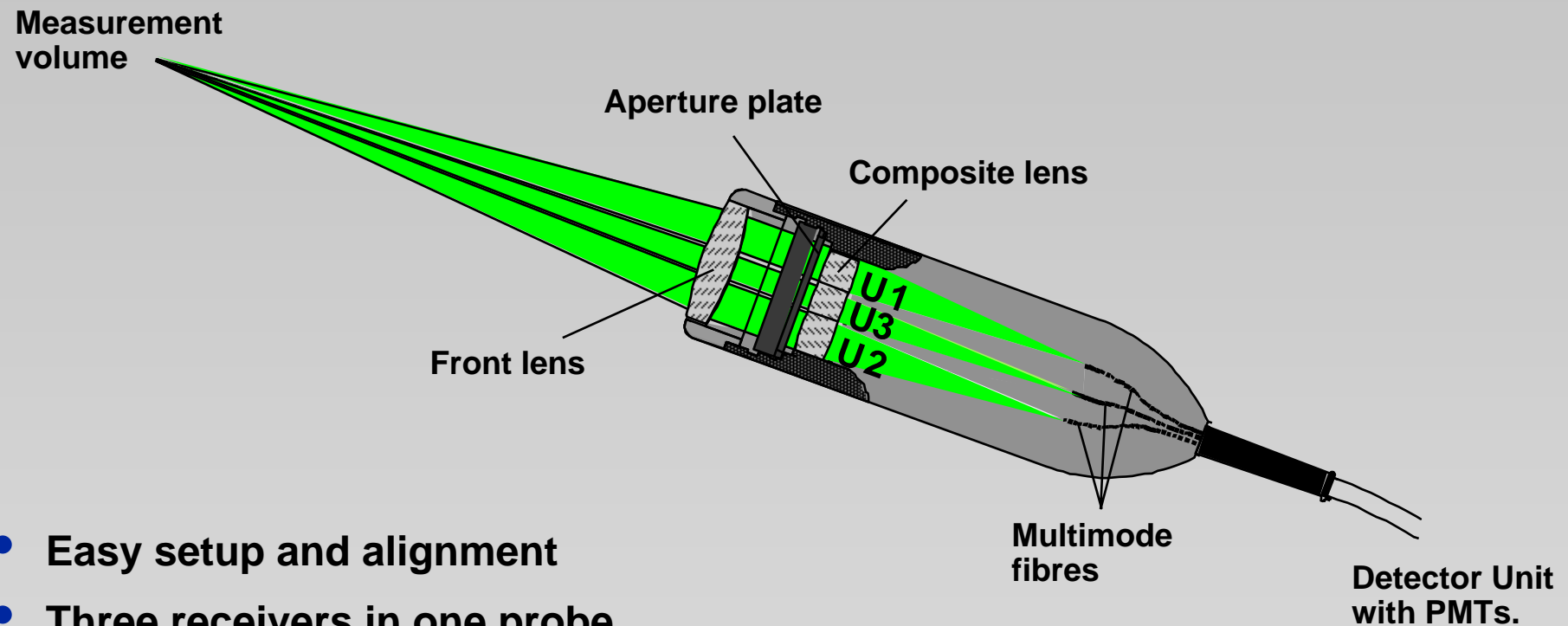

- Easy setup and alignment
- Three receivers in one probe
- Exchangeable aperture masks
- Up to three velocity components

Size range adaptation

- For a given optical configuration, the distance between the receiving apertures can be changed to adapt the size range.
- This can be achieved by exchanging the aperture mask in the receiving probe.
- The Dantec FiberPDA has a set of three different masks:

A: small size range

B: medium size range

C: large size range

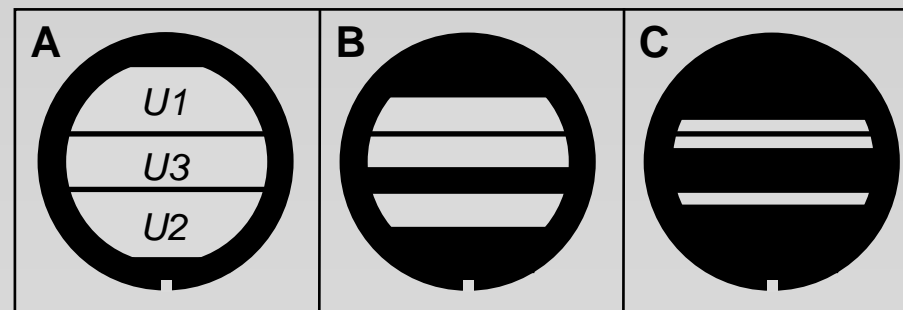

Effective PDA measurement volume

The effective size of the measurement volume is determined by:

- the diameter of the intersection volume of the transmitting beams
- the width of the projection of the slit shaped spatial filter which is mounted in front of the receiving fibers

The effective PDA measurement volume is much smaller than the intersection volume of the transmitting laser beams.

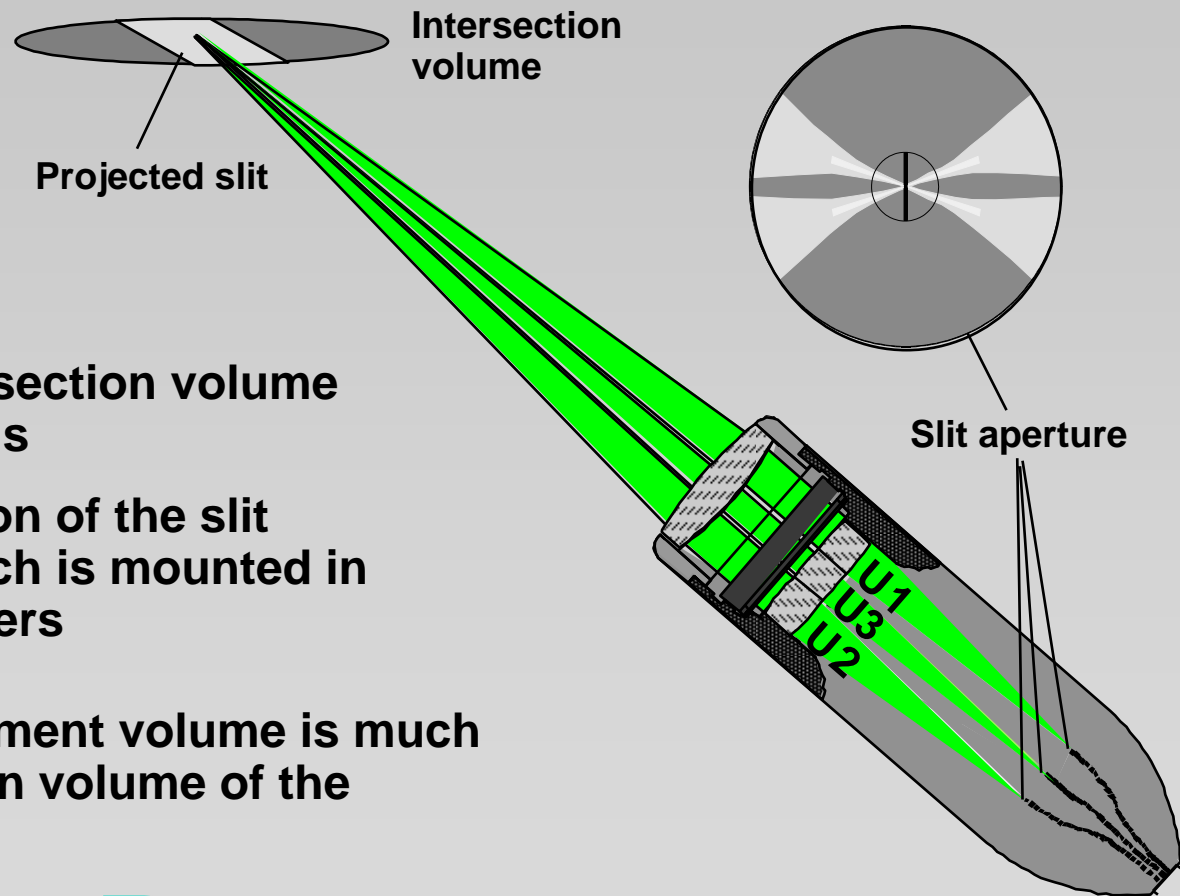

Sources for measurement uncertainties

- Oscillations in phase-diameter curve
- Low SNR due to low intensity or extinction
- Phase changes due to
 - surface distortions
 - inhomogeneous particles
 - multiple scattering effects
- Gaussian intensity profile in the measurement volume
- Slit effect

Trajectory effect / Gaussian beam effect

- Depending on the trajectory of the particle, the detected scattered light is dominated either by refraction or reflection. This is caused by the Gaussian intensity profile across the measurement volume.
- This effect becomes noticeable for large transparent particles ($d_p > \text{ca. } 50\%$ of meas. vol. diameter)

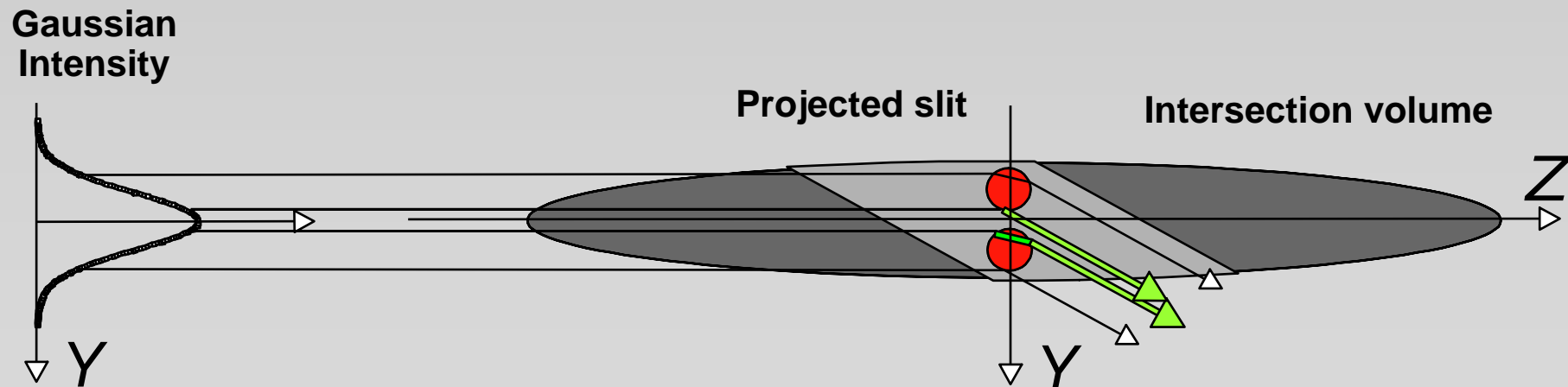

Slit effect

- Due to the projection of the receiving slit aperture, the unwanted scattering mode becomes dominating for particle trajectories at one edge of the slit projection.

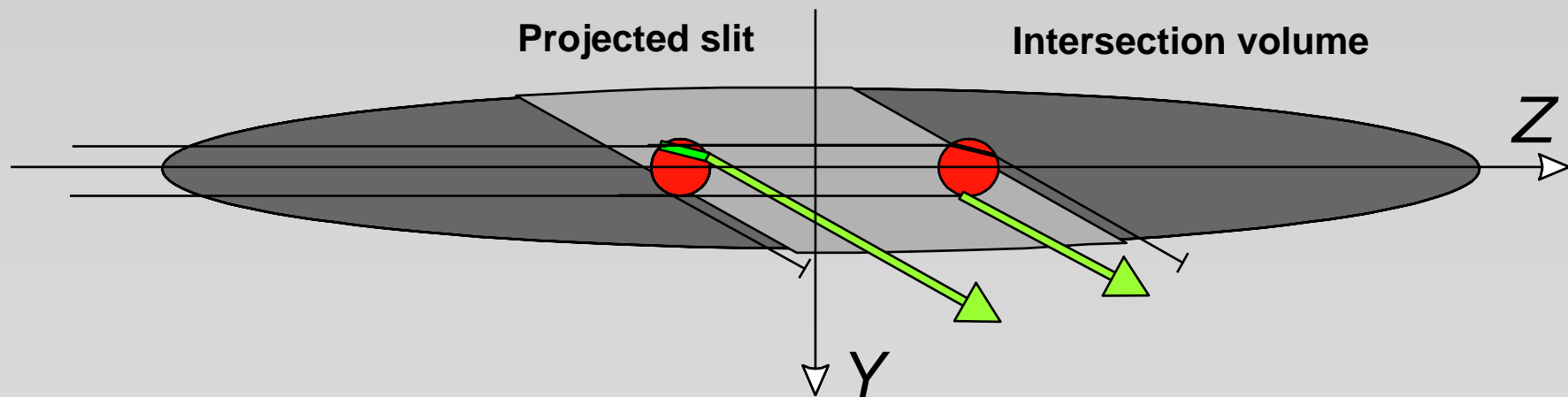

The DualPDA

- Measurement errors due to trajectory and slit effects are eliminated.
- Particularly optimized for applications to sprays with transparent droplets.
- Enables improved concentration and mass flux measurements.
- Provides the ability to reject non-spherical droplets.

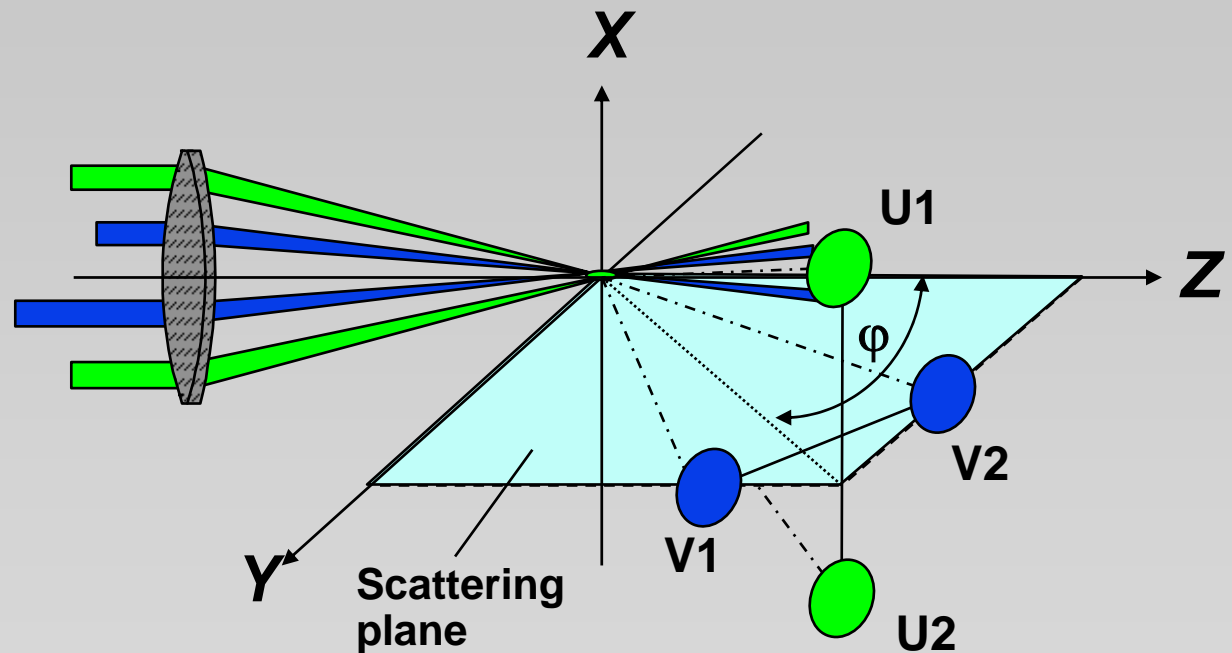

Components of the DualPDA

Conventional PDA

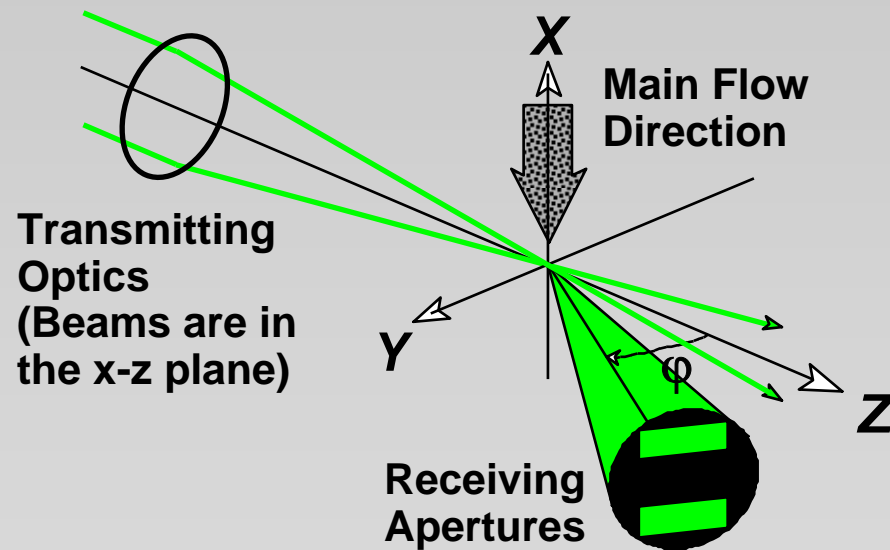

Planar PDA

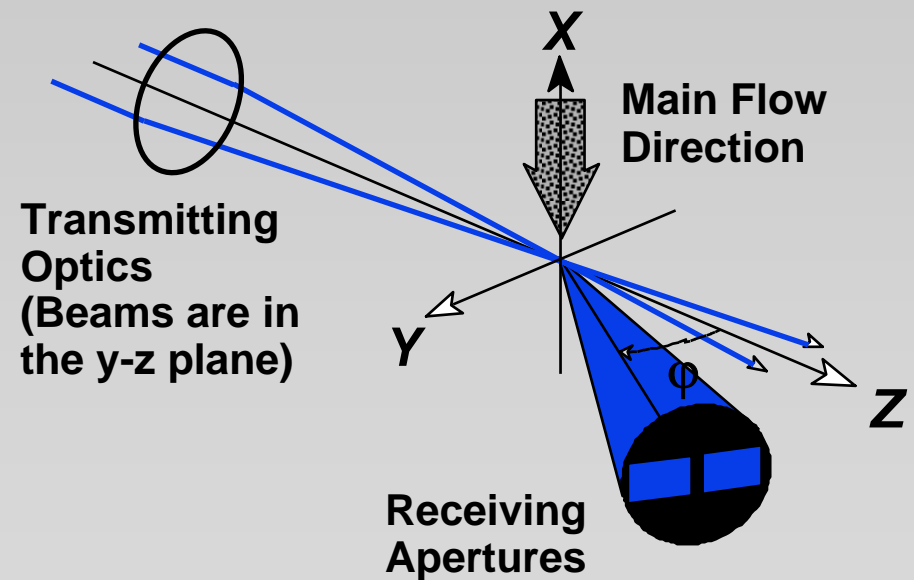

Configuration of the DualPDA

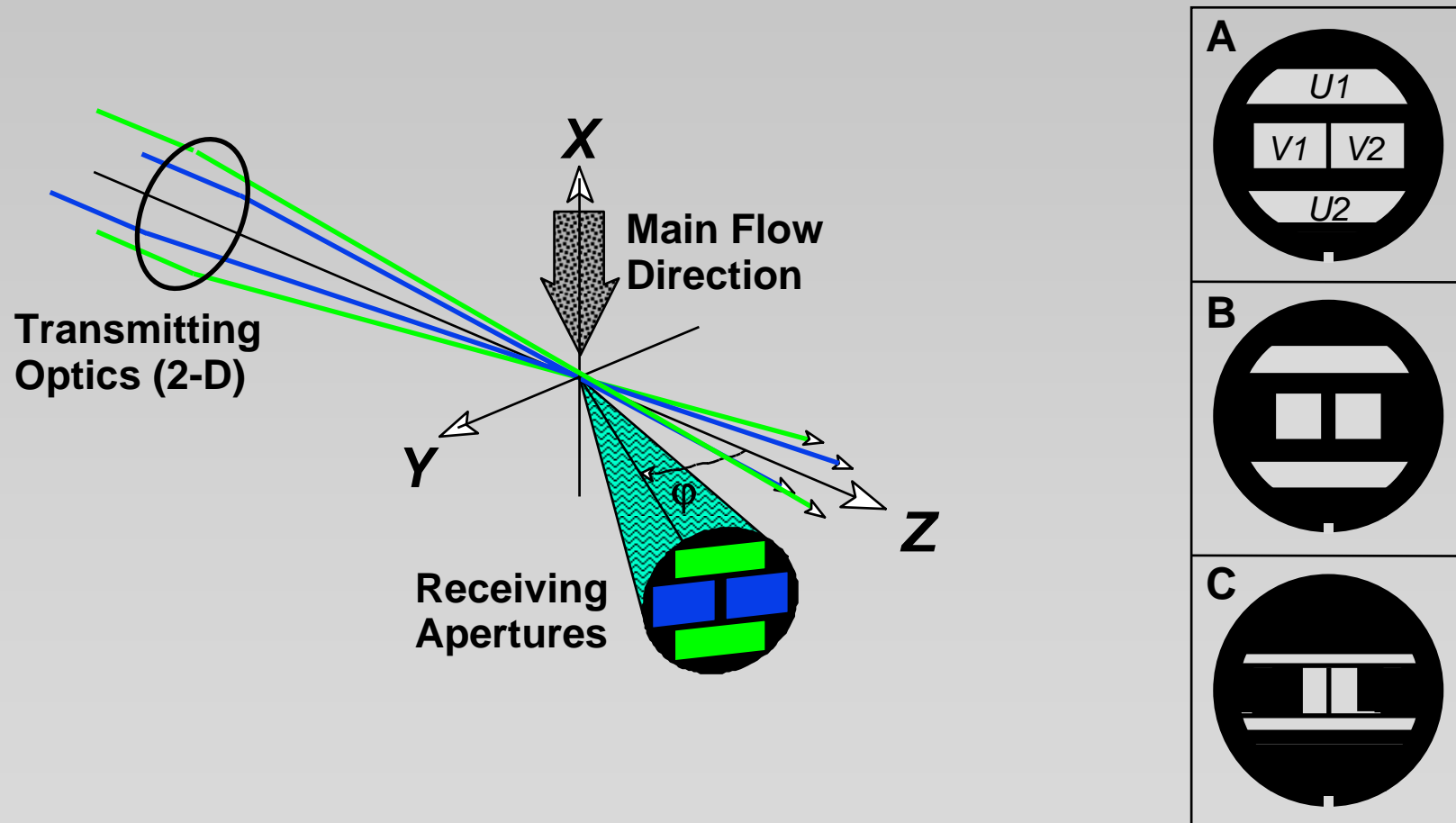

Comparison measurements

Measurement with a standard PDA

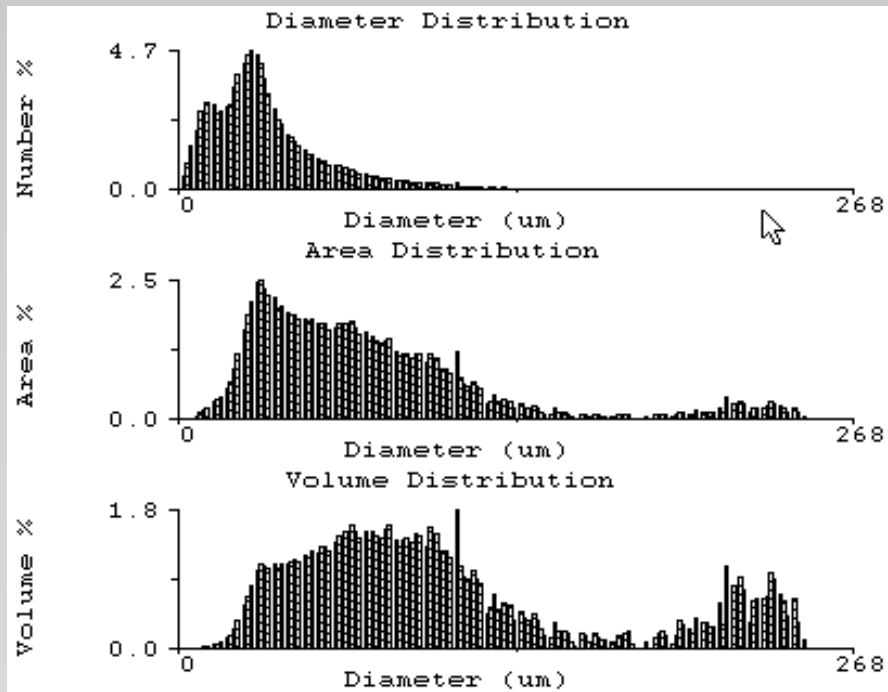

Measurement with a DualPDA

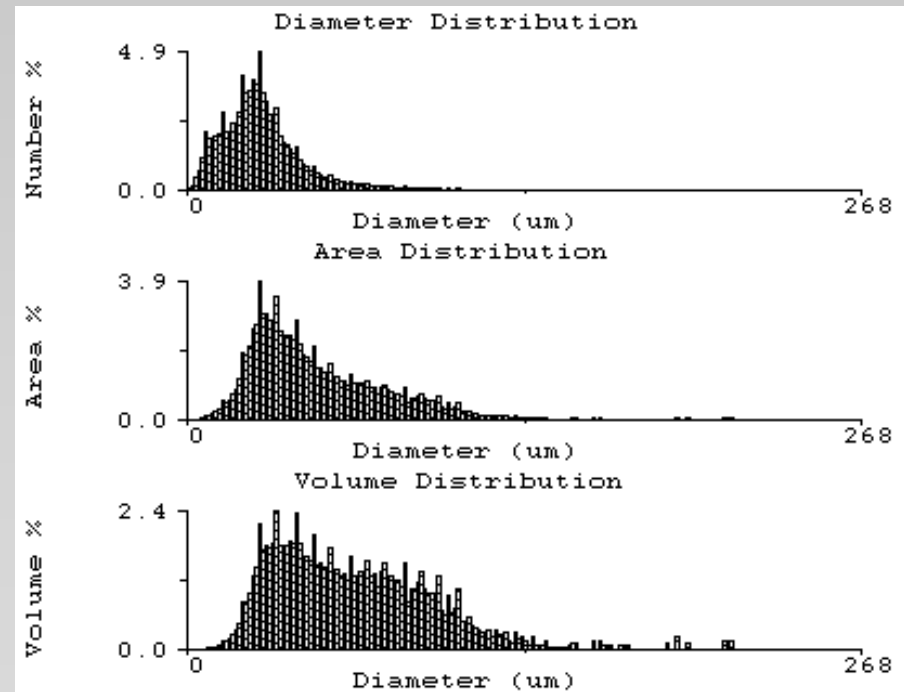

Improved mass flux measurements

- The DualPDA can measure volume and mass flux with better accuracy.

This is confirmed by comparing the results from a patternator and the DualPDA.

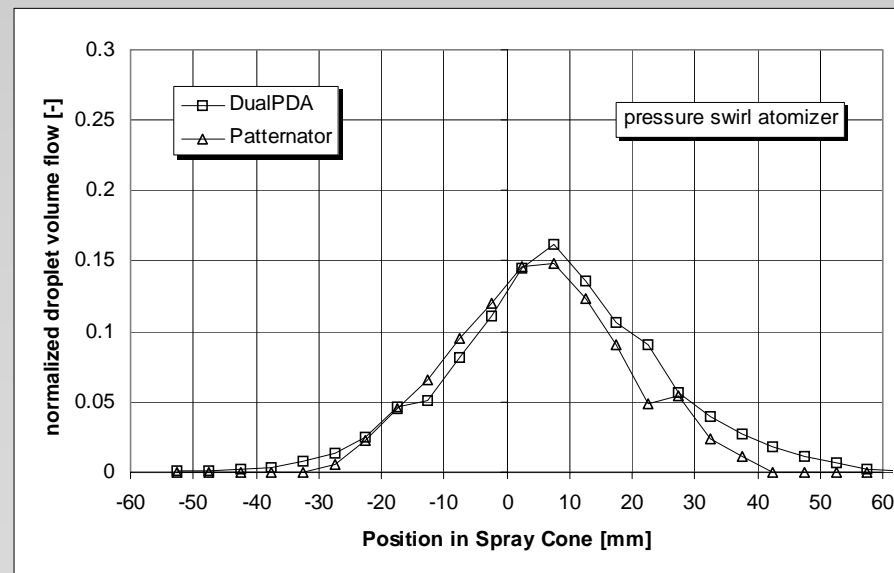
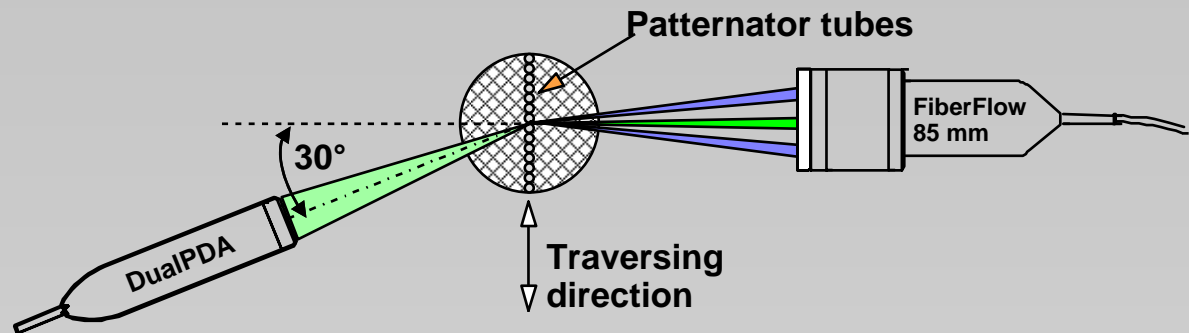

Applications

- **Sprays and liquid atomization processes**
 - Water sprays
 - Fuel-, diesel injection
 - Paint coating
 - Agricultural sprays
 - Medical, pharmaceutical sprays
 - Cosmetic sprays
- **Powder production**
 - Spray drying
 - Liquid metal atomization
- **Bubble dynamics**
 - Cavitation
 - Aeration
 - Multiphase mass transfer

Automotive Fuel Injection

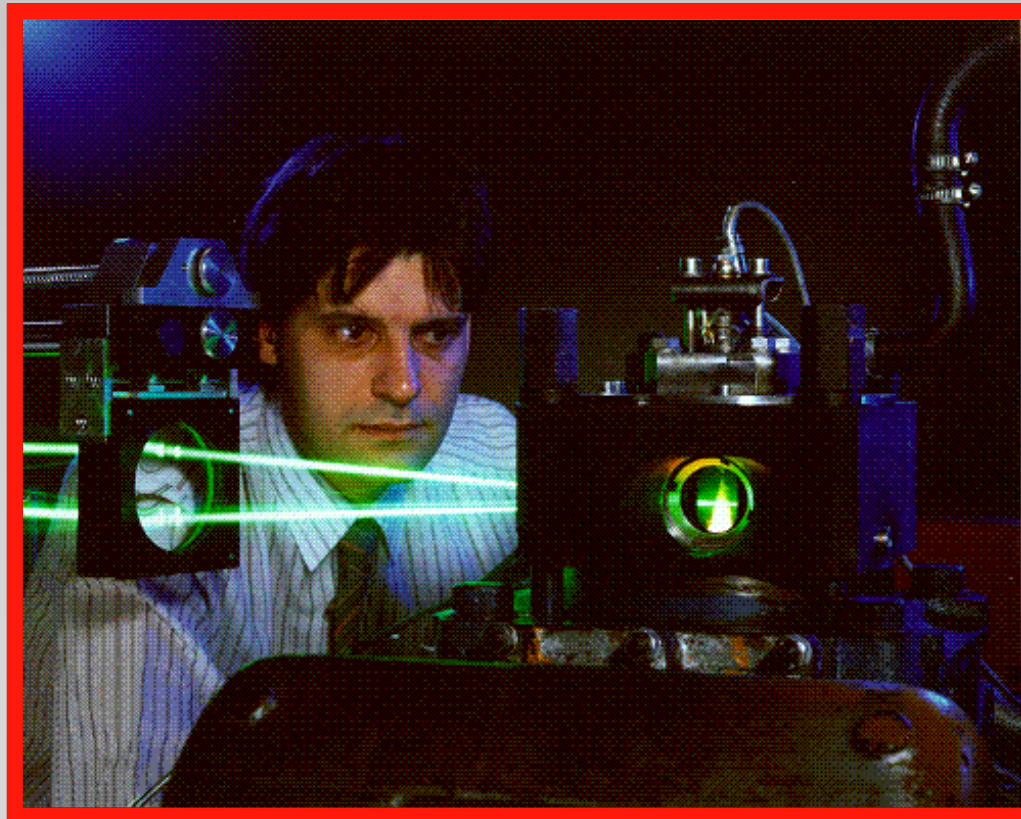

Photo: AVL, Graz, Austria

Nozzle Design



Photo: Gustav Schlick GmbH & Co., Untersiema, Germany

Aircraft Engine Fuel Injection

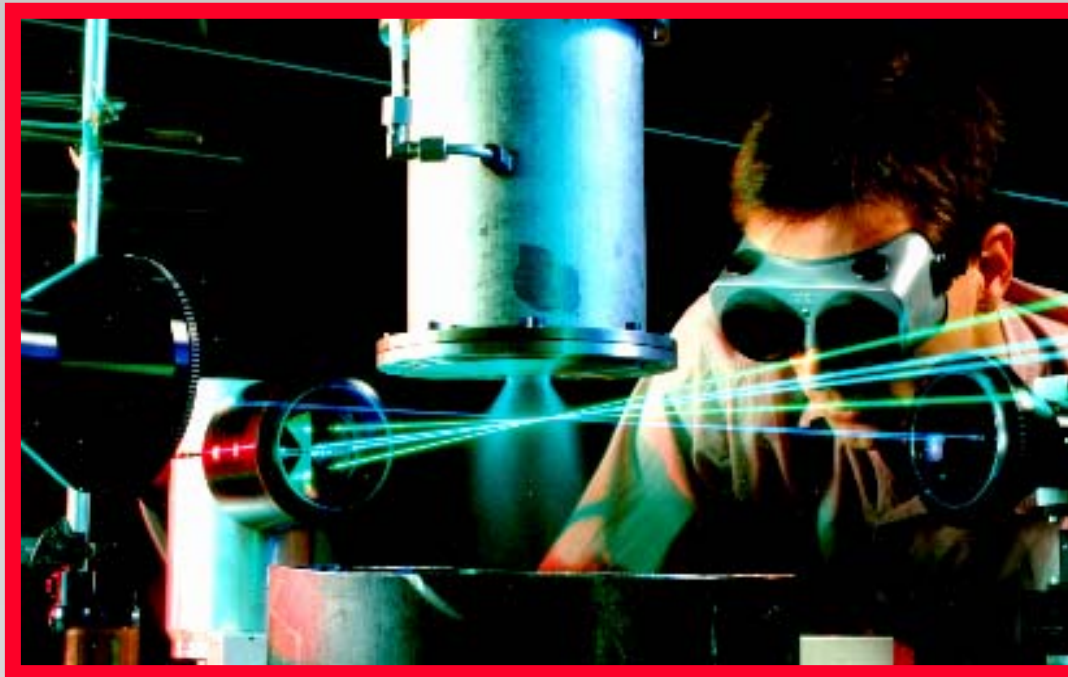

Photo: DLR, Institut für Antriebstechnik, Köln, Germany