



WS 12 Aerodynamic Performance

University Research Projects

Wheel/Wheelarch Drag

Jeff Howell

Tata Motors European Technical Centre

Contents

Drag breakdown

Wheel/wheelarch drag component

Moving ground wind tunnels

Cranfield model rig

Test data

Comments

Conclusions

WS12 Aerodynamic Performance

Drag Breakdown

In crude terms the aerodynamic drag contributions of a typical passenger car can be split 50:50 into styled and 'unstyled' surfaces.

Styled Surfaces

Front end	7%
Skin friction	10%
Mirrors	3%
Rear end	30%

'Unstyled' components

Cooling drag/ Engine bay	6%
Underfloor	12%
Wheels/wheelarches	32%

Interference

These numbers are indicative only, they will vary depending on the type of vehicle and one surface interferes with another.







Wheel Drag Component

Pfadenhauer et al. $\Delta C_D = -0.102$
Audi A3 standard floor $C_D = 0.32$ 32%

Mercker et al. $\Delta C_D = -0.075$
Opel Calibra smooth floor $C_D = 0.24$ 32%

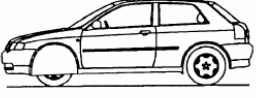
80% of drag penalty from exposed lower wheel.

Main drag reduction from front wheel/wheelarch.

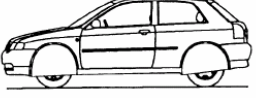
configurations without wheels (without wheels and wheel arches covered)	C_D		difference		C_D		conf. with wheel arches covered (only wheel arches covered)
	ΔC_D		<-	->		ΔC_D	
	Ref.	0.316	0.000		0.316 *	Ref.	
	0.042	0.274	0.029		0.303	0.013	
	0.057	0.259	0.051		0.310	0.006	
	0.102	0.214	0.080		0.294	0.022	

* Values have been measured with stationary wheels in a different wind tunnel and have been shifted to same level as left column for ease of comparison

Wheel/wheelarch Drag Measurement

To identify aerodynamic benefits from the wheel and wheelarch ideally requires the rotation of the wheel to be simulated.

While most European automotive wind tunnels employ moving ground with wheel rotation, no full scale facility exists in the UK.

These facilities are expensive and the project only allocated restricted access as a sign off measure.

Many model scale wind tunnels in the UK have moving belt capability and it was decided to build a rig which would allow drag reduction opportunities from wheels and wheelarches to be investigated at a reasonable scale.

Cranfield had previously acquired the old Rover wheelrig, which had been used in the MIRA MWT (which no longer exists).

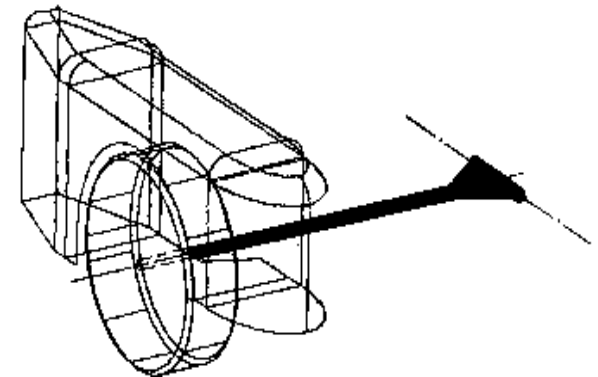

WS12 Aerodynamic Performance

Full Scale moving ground wind tunnel



Classic 5 belt system.

In Europe: Audi, BMW, Volvo, FKFS, Pininfarina, S2A
soon Mercedes-Benz, Porsche.

DNW and BMW have wide belt systems

No UK facility

WS12 Aerodynamic Performance

Cranfield University Wheel rig.

Rebuilt and enlarged Rover wheel-rig

Cranfield 8' x 6' wind tunnel with moving belt ground simulation.

To assess effects of wheelarch geometry and aerodynamic aids on drag reduction of wheel and wheelarch assembly.

Drag measurement from wheel and shroud obtained separately.

Wheel drag includes rotational wheel drag, (windage loss).

Wheel approx
80% scale



WS12 Aerodynamic Performance

Cranfield University Wheel rig.

Wheel shroud mounted to overhead strut
with internal balance.

Wheel mounted separately from outrigger
struts pivoted from outside the belt.
Wheel balance at outboard end of strut.

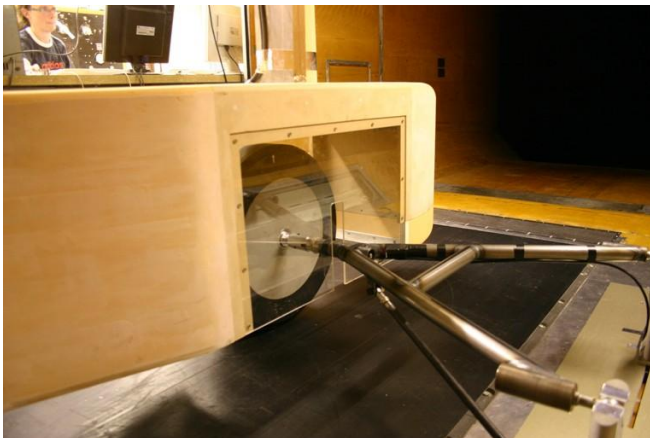

Tare drag obtained with wind-off + low belt speed.

WS12 Aerodynamic Performance

Wheel-rig Configurations



Effect of adding wheel to basic faired body

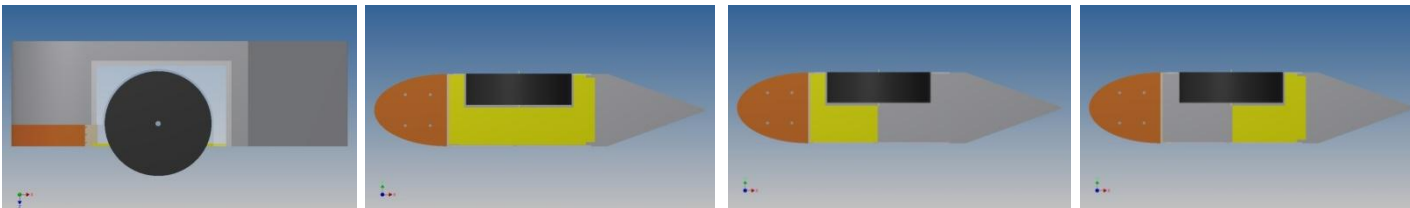

Effect of progressively closing underside from front and rear.

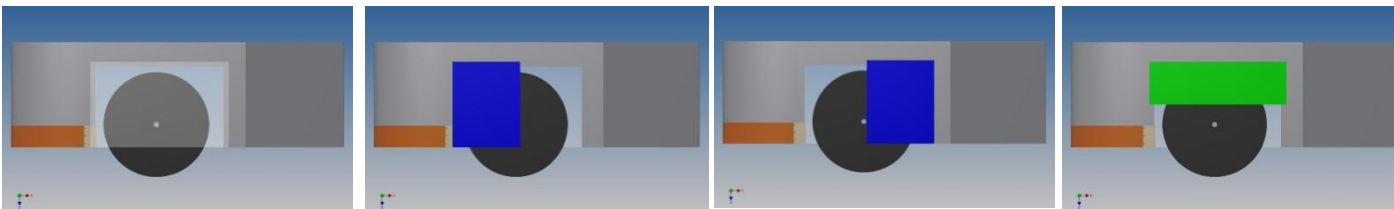

Effect of progressively closing wheelarch opening from front, rear and top.

Wheel-rig Configurations (cont)

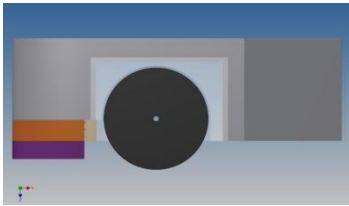

Effect of adding full width bib spoiler – variable depth

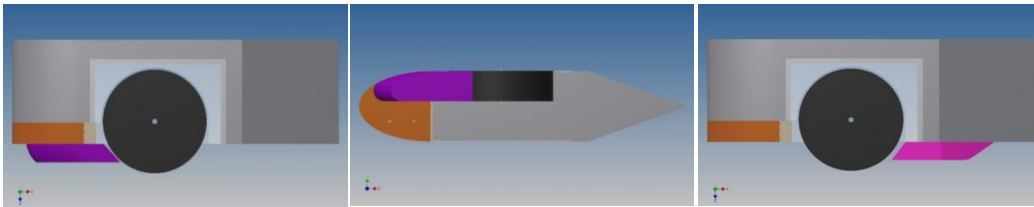

Effect of adding wheel width fairing at front or rear of wheel – variable depth

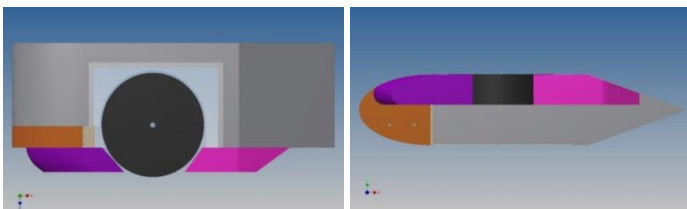

Effect of adding wheel width fairing at front and rear of wheel

Additional investigations of simple wheel spoilers and effect of cavity volume

WS12 Aerodynamic Performance

Wheel-rig drag reductions

Configuration	Body C_{DB}	Wheel C_{DW}	Total C_{DT}
Baseline	0.234	0.180	0.414
	ΔC_{DB}	ΔC_{DW}	ΔC_{DT}
1. Sealed underside	-0.036	-0.009	-0.046
2. Sealed wheelarch opening	-0.003	-0.001	-0.004
3. 2+ Sealed underside	-0.034	-0.014	-0.048
4. Front spoiler - 120 deep	+0.117	-0.126	-0.009
5. Front wheel fairing -120 deep	+0.008	-0.066	-0.058
6. Rear wheel fairing – 60 deep	+0.008	-0.021	-0.013
7. Front and rear wheel fairing 120 deep	+0.000	-0.071	-0.071

WS12 Aerodynamic Performance

Wheel-rig drag reductions

Configuration	Body C_{DB}	Wheel C_{DW}	Total C_{DT}
Baseline	0.234	0.180	0.414
	ΔC_{DB}	ΔC_{DW}	ΔC_{DT}
8. Front wheel fairing 120 deep + rear fairing 60 deep	+0.008	-0.094	-0.086
9. As 8 + Sealed underside	-0.023	-0.076	-0.099
10. Rear of wheelarch cavity filled	-0.006	+0.003	-0.003
11. Wheelarch cavity fully filled	-0.015	+0.008	-0.007
Best tested configuration: Front wheel fairing 120 deep + rear fairing 60 deep + sealed underside + rear of wheelarch cavity filled	+0.002	-0.106	-0.104

WS12 Aerodynamic Performance

Example data: Effect of rear wheel fairing depth

Optimum fairing depth at approx 60mm.

Trends are very similar for both ground simulations.

Total drag higher for rotating wheel.

Compare with MGWT data where the opposite occurs.

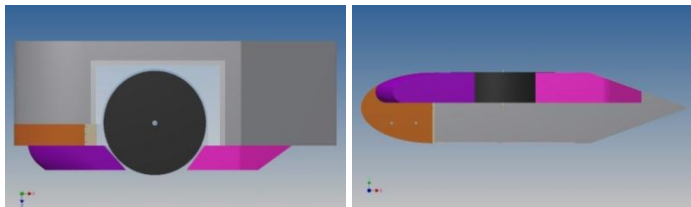

open symbols - wheel stationary
solid symbols – wheel rotating

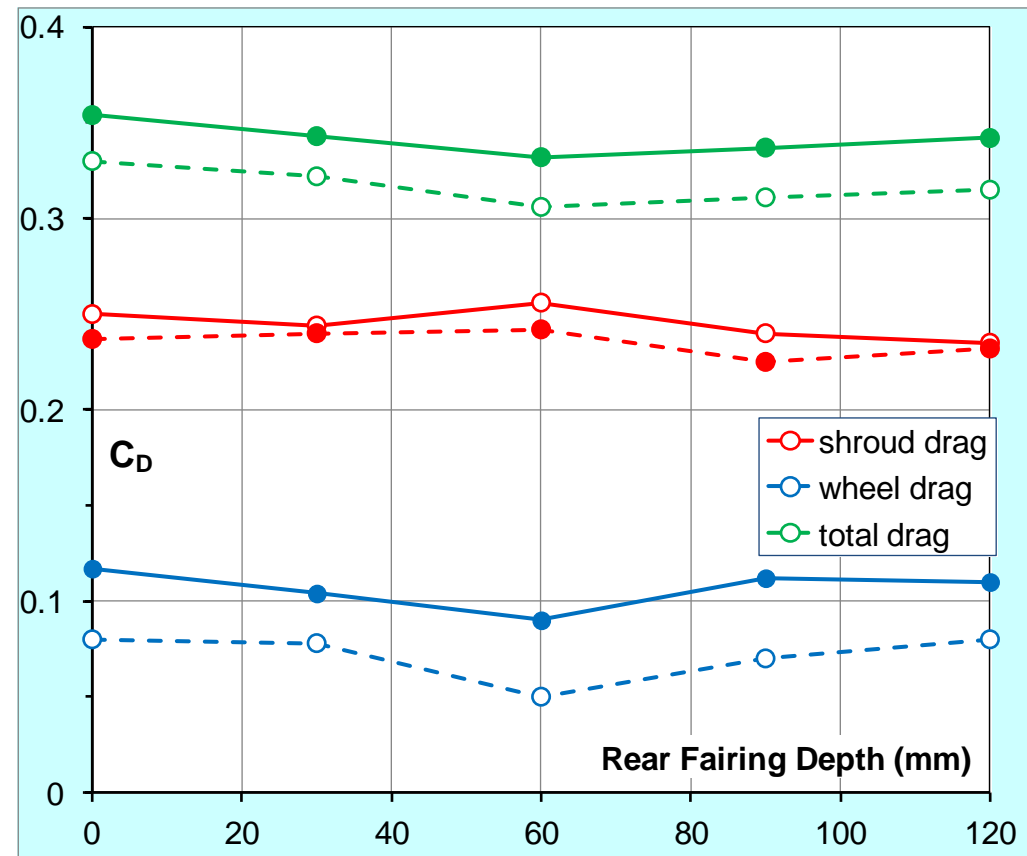

Comments

1. Simulation issues:

The simulation does not account for the crossflow experienced on front wheels of a typical car, except for the offset of the wheel in the wheelarch.

The wheel is represented by a simple chamfered thick disc. A real wheel will create more pumping action within the wheelarch.

The wheel arch is empty, except for a plain axle, whereas a real wheelarch includes suspension components, wheel hubs, brake assemblies and steering arms.

2. The large benefits will require active devices for implementation on real cars.

Comments 2.

3. How to relate the drag reductions to real car values.

Some uncertainty exists!

Current approach:

Incremental drag forces are relevant to a single front wheel.

Forces are scaled up to account for model wheel size (~ 80%)

Rear wheel drag is typically approximately half that of the front wheel.

Presented coefficients based on wheel rig frontal area (0.175 m²).

Scale factor: Rig data/FS car = $1.25^2 \times 3 \times 0.175/2.25 = 0.36$.

Conclusions

Significant aerodynamic drag reduction has been obtained from the wheel/wheelarch area of a passenger car as simulated using a simple wheel rig.

Large benefits were found with a fairing in front of the wheel and by closing the underside of the wheelarch cavity.

On real vehicles these benefits can only be realised with active devices as they intrude into ground clearance or interfere with wheel articulation.

Filling the wheelarch cavity increased drag which was not expected.

The beneficial effects of these devices still requires assessment in the real world.



Thank You
to
Cranfield University
for the research input
to LCVTP