

Feature Article

Wind Tunnel Balance System for Vehicle Aerodynamic Developments

Hans Vogt

In vehicle development steps, optimization of aerodynamic properties is often carried out in wind tunnel facilities. The vehicle is placed upon the measuring platform of the balance. The wind tunnel balance now allows the precise measurement of six forces and moments induced by the air flow. The HORIBA wind tunnel balance system can be equipped with a moving ground system which makes the air flow at the underside and around the wheels much more realistic. This moving ground system is built up of a central moving belt unit which is running at wind speed between the wheels and of four wheel spinning units which are rotating the wheels with wind speed. In this case the four wheel spinning units are also part of the force measuring system of the balance. Maximum speeds of up to 250 km/h are possible.

Introduction

Vehicle development steps and optimization of aerodynamic properties are often carried out in wind tunnel facilities. The improvement of vehicle aerodynamics is an important step to optimize fuel consumption, driving comfort, performance and acoustics. Even though many investigations can be done with numerical methods, still realistic tests with true air flow simulation around the vehicle are indispensable.

In a wind tunnel the air flow at the underside of the vehicle is not completely realistic, because the vehicle is not moving in the tunnel. In real life the vehicle is moving while the air is at rest. In the wind tunnel a boundary layer exists close to the test section floor. In modern wind tunnels special methods and equipment are used to improve air flow simulation at the underside of the vehicle.

The demand for new modern wind tunnels with the capability of air flow simulation especially at the underside of the vehicle combined with a high accuracy of force measurement is now even growing worldwide. The HORIBA wind tunnel balance system together with its integrated moving ground system (Figure 1) fulfils both requirements excellently.

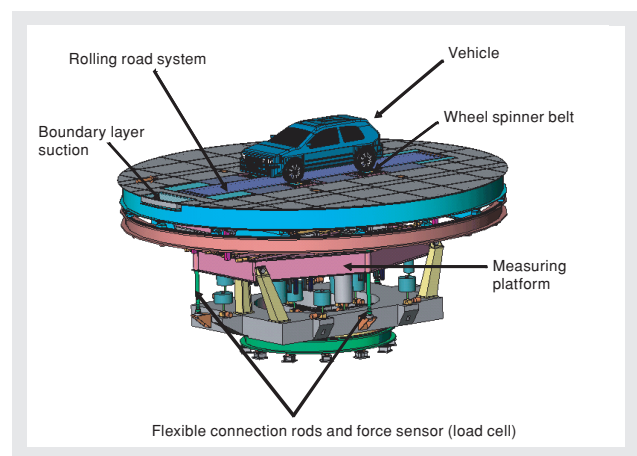

Figure 1 HORIBA Wind Tunnel Balance with Turntable and Moving Ground System

Wind Tunnel Balance

The HORIBA wind tunnel balance is a platform-type balance. A rigid, massive platform is held statically fixed at six points. These six points are connected (three in horizontal direction, three in vertical direction) to a frame with flexible connection rods. At the end of each rod a force sensor (load cell) is integrated. A computer program is used to calculate the forces F_x (longitudinal-force), F_y (lateral-force), F_z (vertical-force) and the three moments M_x (roll-moment), M_y (pitch-moment), M_z (yaw-moment) from the six force sensor signals (Figure 2). This 'computer-separation' method is to be more accurate

than other balance types using mechanical separation methods because it is mechanical loss free. Also, the method has advantages that the system can have simple configuration and have no moving parts.

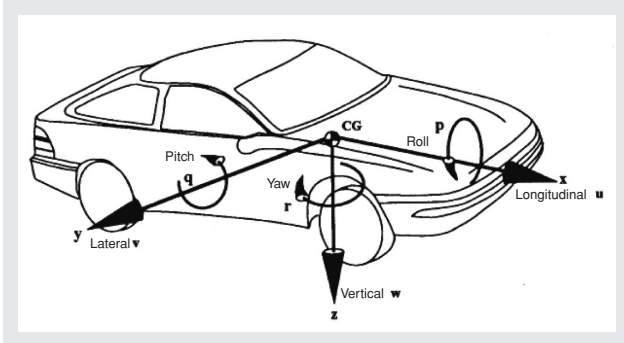

Figure 2 Three Forces and Moments Measured with the Wind Tunnel Balance

The advantage of the HORIBA wind balance system is a very robust, simple, long term stable and maintenance free construction of the balance. No lever systems and no hydraulics are used. Also, no tare compensation system is necessary. Even small force components in the order of 1 N can be measured while a static preload of approx. 150000 N in vertical-force direction is applied caused by the mass of the balance platform, wheel spinner masses and vehicle mass. By using high quality load cells and a precise high resolution digital amplifier system, highest measurement accuracies in the order of 0.02 % to 0.05% of full measuring range can be achieved. The measuring range of vertical force is up to 15000 N. Additionally the cross interference of different force components is eliminated by special calibration and data evaluation methods.

HORIBA Wind Balance Systems are delivered in three standard sizes for testing of models or in any size according to customer requirements for full scale vehicles. The HORIBA wind tunnel balance systems can also be used for other test objects such as aircraft models, ship models, motor bikes and others.

All functions of the balance system can easily be remote controlled from a host computer with an Ethernet TCP/IP link. Additionally a stand-alone operation program is supplied.

Figure 3 shows the balance platform under assembly. The platform is connected with flexible rods to a frame at an early stage of the balance erection. On top of the platform the servo motors of the wheel spinners, which are mounted on the platform, can be seen.



Figure 3 Balance Platform Held Statically Fixed

Turntable and Vehicle Lift System

To rotate the vehicle around the vertical z-axis, the wind tunnel balance and the test section floor can be rotated. A vehicle lift unit is integrated in the balance system to lift the vehicle up to 1800 mm allowing fast modification work in the wind tunnel on the underside of the vehicle. Figure 4 shows the turntable and the lift units of the wind tunnel. The lift units are integrated around the wheel spinner units.



Figure 4 Lift System

Moving Ground System

This moving ground system (also called '5-belt system') is built up of a central moving belt unit (also called 'rolling road system') which is running at wind speed between the wheels and of four wheel spinning units which are rotating the wheels with wind speed. The center belt unit is integrated into the turntable without contact to the balance platform. The wheels of the vehicle are standing on the four wheel spinner belts which are mounted on the platform. The aerodynamic forces of the vehicle are thus transmitted to the platform via the wheel spinners and the rocker panel restraint system, which holds the vehicle in

Feature Article Wind Tunnel Balance System for Vehicle Aerodynamic Developments

position. Additional to the moving ground system, a boundary layer suction system can be placed in front of the center belt unit. Figure 5 shows a vehicle positioned on the four wheel spinners of the wind tunnel. The vehicle is held in position with four rocker panel restraints.

The polymer belt of the center belt unit is driven by two servo drives with a maximum electric power of 250 kW. The lateral belt position is detected with an optical laser position sensor. Belt lateral position and belt tension is controlled and adjusted fully automatically with a tracking station which is driven by two servo drives. To prevent the belt from lifting off due to aerodynamically induced low pressure below the vehicle, the frame of the center belt unit is equipped with approximately 8 suction chambers to suction the belt. Maximum speeds of up to 250 km/h are possible. As an alternative to center belt systems with polymer belts, HORIBA also offers center belt systems running with steel belts. With steel belts, maximum velocities up to 300 km/h are possible.

The wheel spinner are using polymer V-belts. Tracking of the belt system is not necessary, because the belt is driven by the belt wedges on the drums (Figure 6).



Figure 5 Wind Tunnel Balance with Turntable and Moving Ground System



Figure 6 Wheel Rotation with Wheel Spinner

Conclusion

HORIBA Wind Tunnel Balance systems have a proven track record for reliability and measurement accuracy unparalleled by any other supplier of such equipment in the world. The HORIBA Wind Tunnel Balance Systems can be used as modern automotive wind tunnel facilities where simulation quality, measurement accuracy, robustness and easy handling of the system are required.



Hans Vogt

HORIBA Europe GmbH
Business Unit Brake & Windtunnel
Ph.D.